

1996 Mazda MX-5 Miata

1995-96 ENGINES 1.8L 4-Cylinder

1995-96 ENGINES

1.8L 4-Cylinder

ENGINE IDENTIFICATION

NOTE: For repair procedures not covered in this article, see **ENGINE OVERHAUL - GENERAL INFORMATION** article in **GENERAL INFORMATION** section.

Engines can be identified by engine model and number. See **ENGINE IDENTIFICATION CODE**. Engine model and number are stamped on flange at upper right rear of cylinder block deck, as viewed from flywheel.

ENGINE IDENTIFICATION CODE

Application	Code
Miata (1.8L DOHC)	BP

ADJUSTMENTS

VALVE CLEARANCE ADJUSTMENT

NOTE: Valve clearance is not adjustable. Some Hydraulic Lash Adjuster (HLA) noise may occur during engine start-up. Noise should disappear after engine reaches normal operating temperature. If noise persists and oil level is okay, change engine oil. If oil change does not reduce noise, check with manufacturer for modified HLA.

REMOVAL & INSTALLATION

NOTE: For reassembly reference, label all electrical connectors, vacuum hoses and fuel lines before removal. Also place mating marks on engine hood and other major assemblies before removal.

FUEL PRESSURE RELEASE & PRIMING

Releasing Pressure

Locate and remove fuel pump relay from under left side of dash, near steering column. Start engine and allow to stall. After engine stalls, attempt to restart engine to ensure no residual pressure exists. Turn ignition off and reinstall fuel pump relay. When disconnecting fuel hoses, cover connection with shop rag to catch fuel leakage. To avoid excessive cranking after servicing, prime fuel system before starting engine.

Priming System

Ensure fuel system is closed. Connect jumper wire between F/P and GND terminals of data link connector. See **Fig. 1** . Turn ignition on for about 10 seconds and check for fuel leaks. Turn ignition off and disconnect jumper wire.

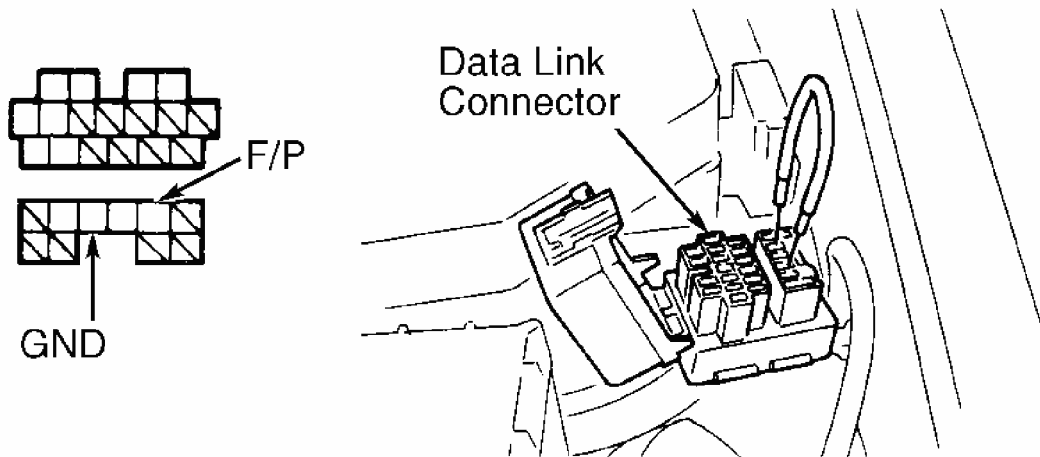

G93B84500

Fig. 1: Identifying Data Link Connector Terminals (Typical)
Courtesy of MAZDA MOTORS CORP.

COOLING SYSTEM BLEEDING

CAUTION: If engine overheats during procedure, system contains excessive air. Stop engine and allow it to cool, then repeat step 1).

1. Slowly pour coolant into radiator at a rate of 1.1 qt. (1.0L) per minute maximum until coolant is level with filler port. Fill coolant reservoir to "F" mark. Securely install radiator cap. Start engine.
2. Operate engine at idle until normal operating temperature is reached. If coolant level warning light illuminates during warm-up, turn engine off and check drain plug and coolant hoses for leaks. Operate engine at 2200-2800 RPM for 5 minutes. Stop engine and allow to cool.
3. Repeat steps 1) and 2). Check coolant level. If engine coolant is not level with filler neck, repeat entire procedure. If engine coolant is level with filler neck, fill reservoir to "F" mark.

ENGINE

NOTE: On models with audio anti-theft system, radio will not operate if power to radio is cut. Obtain code from customer to reactivate radio. To reactivate radio after reconnecting power supply, turn ignition switch to ACC position. Press and hold FF and REW buttons until CODE is displayed. Again press and hold FF and REW buttons until bars (----) are displayed. Use preset button No. 1 to enter first number. Use preset buttons No. 2 to enter second number, 3 for third number, etc. Press FF and REW buttons for about 1.5 seconds until a beep is heard. After 5 seconds, flashing CODE will disappear and radio will operate.

Removal

1. Release residual pressure from fuel system. See **FUEL PRESSURE RELEASE & PRIMING** . Disconnect negative battery cable from trunk-mounted battery. Reference mark and remove hood. Raise vehicle and remove engine undercover. See **Fig. 2** . Drain engine, transmission and cooling system fluids.
2. Remove transmission. For transmission removal procedure, see TRANSMISSION REMOVAL & INSTALLATION - A/T article in AUTOMATIC TRANS SERVICE section or TRANSMISSION REMOVAL & INSTALLATION - M/T article in MANUAL TRANS SERVICE section.

1996 Mazda MX-5 Miata

1995-96 ENGINES 1.8L 4-Cylinder

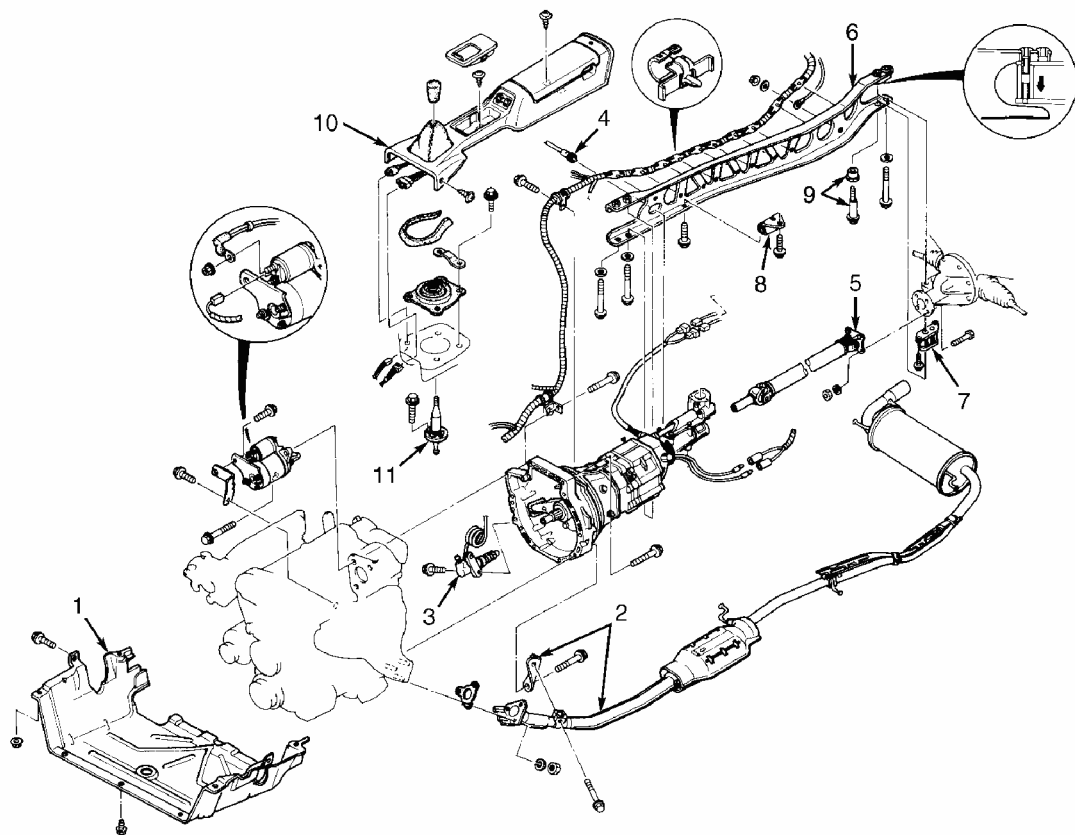

1. Undercover

2. Exhaust Downpipe & Bracket

3. Clutch Release Cylinder

4. Speedometer Cable

5. Drive Shaft

6. Power Plant Frame (PPF)

7. PPF/Differential Mounting Spacer

8. Transmission-To-PPF Bracket

9. Reamer Bolt & Spacer

10. Console

11. Shift Lever

G91E01836

Fig. 2: Removing & Installing Drive Train Components
Courtesy of MAZDA MOTORS CORP.

3. Remove all cooling system hoses and A/T oil cooler hoses at radiator (if equipped). Remove radiator and cooling fans as an assembly. Remove all drive belts. DO NOT disconnect power steering hoses or A/C compressor hoses. Unbolt power steering pump and A/C compressor from engine, and wire aside.
4. Remove air cleaner assembly. See **Fig. 3**. Remove throttle cable. Note locations and disconnect all necessary electrical connectors, ground wires, vacuum hoses, fuel hoses, coolant hoses and control cables for engine removal. Plug all fuel hoses to prevent leakage. Remove engine mount nuts and remove engine.

1996 Mazda MX-5 Miata

1995-96 ENGINES 1.8L 4-Cylinder

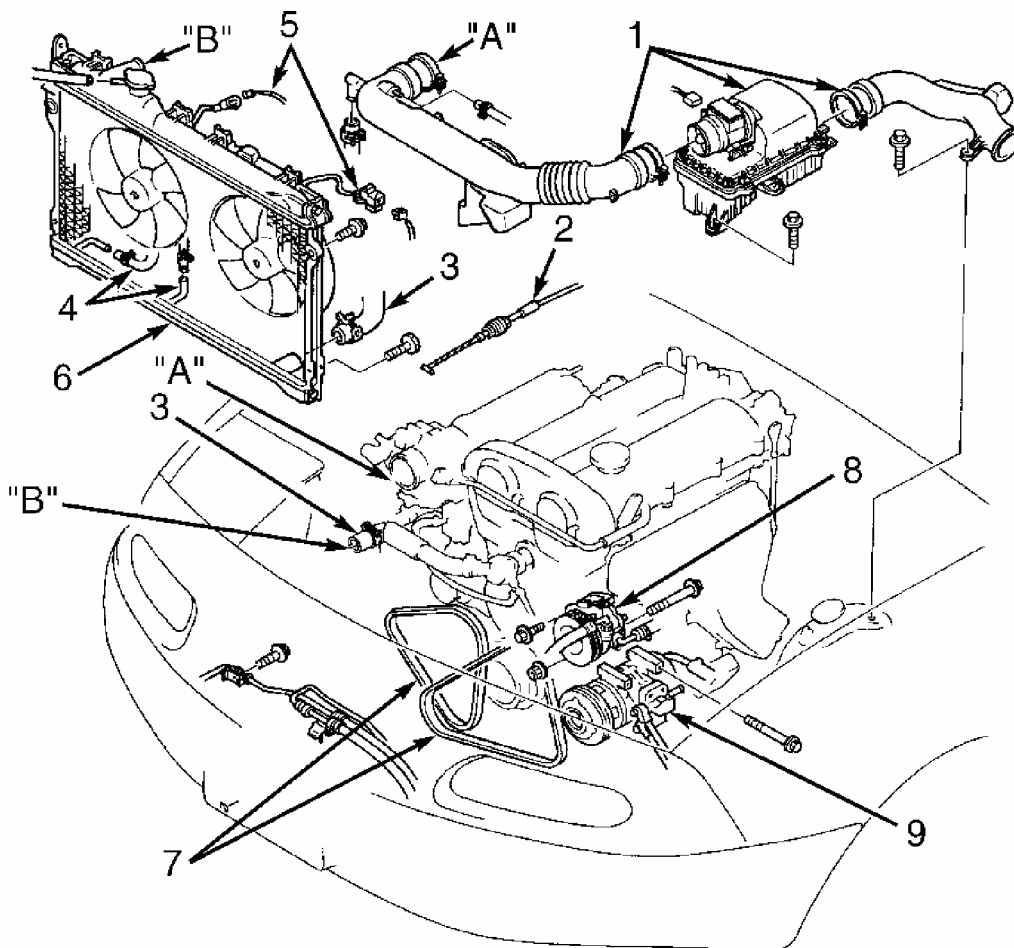

1. Air Cleaner Assembly

2. Throttle Cable

3. Radiator Hoses

4. Oil Cooler Hoses (A/T)

5. Cooling Fan Connectors

6. Radiator/Cooling Fan Assembly

7. Drive Belts

8. Power Steering Pump

9. A/C Compressor

96C07941

Fig. 3: Removing Engine Components
Courtesy of MAZDA MOTORS CORP.

NOTE: Proper installation of Power Plant Frame (PPF) is critical for aligning drive shaft and eliminating harmonic vibrations.

Installation

1. To install, reverse removal procedure. After installing engine mount nuts, mount PPF to transmission and tighten long bolts by hand. Ensure bolt sleeve and PPF/differential mounting spacer are installed to differential housing block.
2. Tighten PPF/differential mounting spacer bolts to 28-38 ft. lbs. (38-52 N.m). See **Fig.**

4. Install PPF to differential. Hand-tighten long bolts. Ensure PPF-to-differential large shank reamer bolt and spacer are properly installed.

NOTE: Reamer bolt is the front long bolt attaching PPF to differential. This bolt aligns PPF with drive train.

- When PPF is properly aligned between transmission and differential, tighten all long mounting bolts to specification. Install rear transmission-to-PPF bracket and tighten to specification. See **TORQUE SPECIFICATIONS** . To complete installation, reverse removal procedure. Before installing M/T shift lever, add gear oil to transmission through shifter hole. Fill all fluids to correct level. Prime fuel system before attempting to start engine. For procedures see **FUEL PRESSURE RELEASE & PRIMING** . Bleed cooling system. For procedures see **COOLING SYSTEM BLEEDING** .

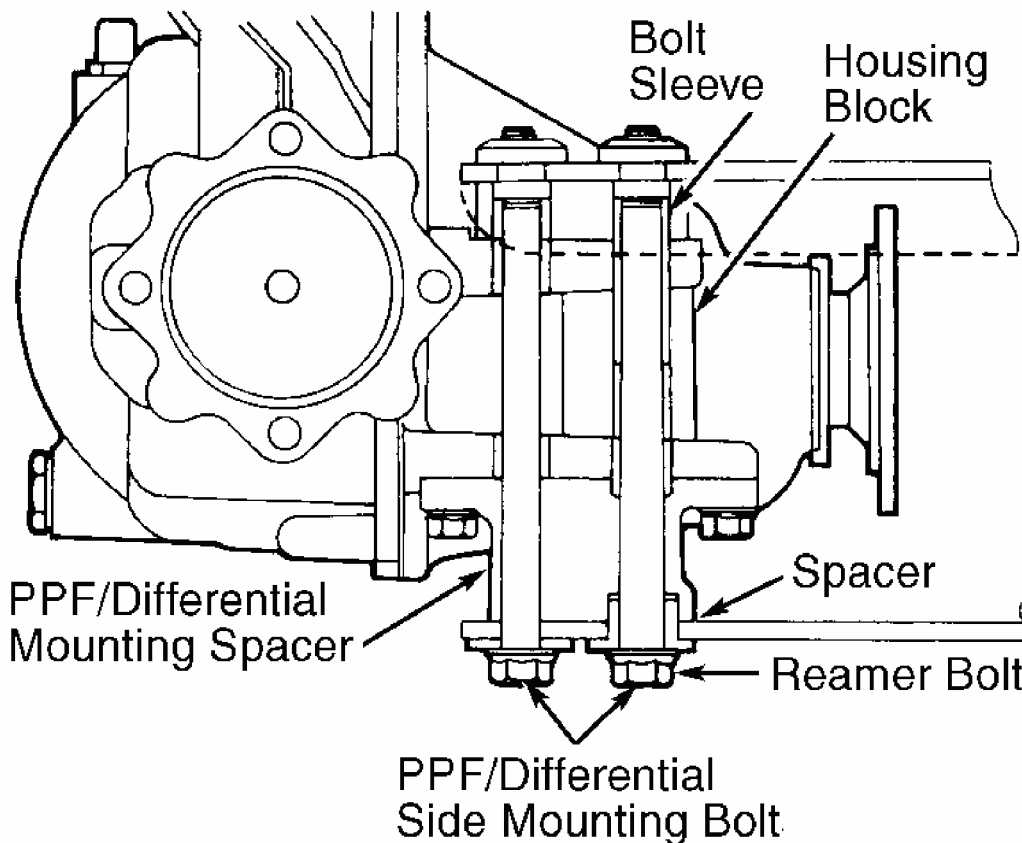

G91I01838

Fig. 4: Locating PPF-To-Differential Reamer Bolt, Sleeve & Spacer
 Courtesy of MAZDA MOTORS CORP.

1996 Mazda MX-5 Miata

1995-96 ENGINES 1.8L 4-Cylinder

Removal

1. Release residual pressure from fuel system. See **FUEL PRESSURE RELEASE & PRIMING** . Disconnect negative battery cable. Drain cooling system. Remove air cleaner assembly and ducting. See **Fig. 3** . Mark and disconnect coolant hoses, vacuum hoses and electrical connectors from intake manifolds.
2. Disconnect throttle cable. Remove fuel lines from fuel rail and pressure regulator. Remove throttle body intake duct housing and throttle body. Remove by-pass air control valve and solenoid valves. Remove upper intake manifold (if equipped).
3. On all models, remove intake manifold support bracket from underneath manifold. Disconnect injector harness connectors, and remove injectors/fuel rail assembly. Remove intake manifold and gasket.

Installation

1. Ensure all gasket surfaces are clean and flat. Using new gasket, install intake manifold to cylinder head. Tighten manifold bolts/nuts evenly to specification, starting from center bolt and alternating outward. See **TORQUE SPECIFICATIONS** . Install support bracket underneath intake manifold.
2. Install gasket and upper intake manifold (if equipped). Tighten bolts/nuts evenly to specification, alternating from top to bottom. See **TORQUE SPECIFICATIONS** .
3. To complete installation, reverse removal procedure. Ensure Throttle cable has .04-.12" (1-3 mm) free play. Ensure injectors twist freely and are not cocked in insulator "O" rings. Refill engine with coolant.

EXHAUST MANIFOLD

Removal & Installation

1. Remove air cleaner intake duct from top of radiator/fan assembly (if equipped). Disconnect oxygen sensor. Remove heat shields. Disconnect downpipe from exhaust manifold. Remove exhaust manifold.
2. To install, reverse removal procedure. Ensure all mating surfaces are clean and flat. Install new gasket to cylinder head. Tighten manifold bolts evenly to specification, starting from center bolt and alternating outward. See **TORQUE SPECIFICATIONS** .

CYLINDER HEAD

Removal

1. Release residual pressure from fuel system. See **FUEL PRESSURE RELEASE & PRIMING** . Drain engine coolant. Note locations and disconnect all necessary electrical connectors, ground wires, vacuum hoses, fuel hoses, coolant hoses and control cables for cylinder head removal. Plug all fuel hoses to avoid leakage.

1996 Mazda MX-5 Miata

1995-96 ENGINES 1.8L 4-Cylinder

2. Remove spark plug wires from spark plugs. Remove all drive belts. Remove water pump pulley. Remove timing belt. See **TIMING BELT** . Remove camshaft/rocker cover.
3. Remove front exhaust pipe. Remove intake manifold support bracket. Loosen all cylinder head bolts evenly, in 3 steps, in reverse of tightening sequence. See **Fig. 5** . Remove bolts and cylinder head assembly.

Inspection

Carefully clean carbon and gasket material from all mating surfaces. Clean threads of cylinder head bolts. Use a tap to clean threads in engine block. Check cylinder head for warpage. Resurface or replace head if it is not within specification. Check valve train components. Replace or resurface components if they are not within specification. See **CYLINDER HEAD** and **VALVES & VALVE SPRINGS** tables under **ENGINE SPECIFICATIONS**.

Installation

Install cylinder head gasket, cylinder head assembly and bolts. Tighten cylinder head bolts in 2 steps and in sequence to specification. See **Fig. 5** . See **TORQUE SPECIFICATIONS** . To complete installation, reverse removal procedure.

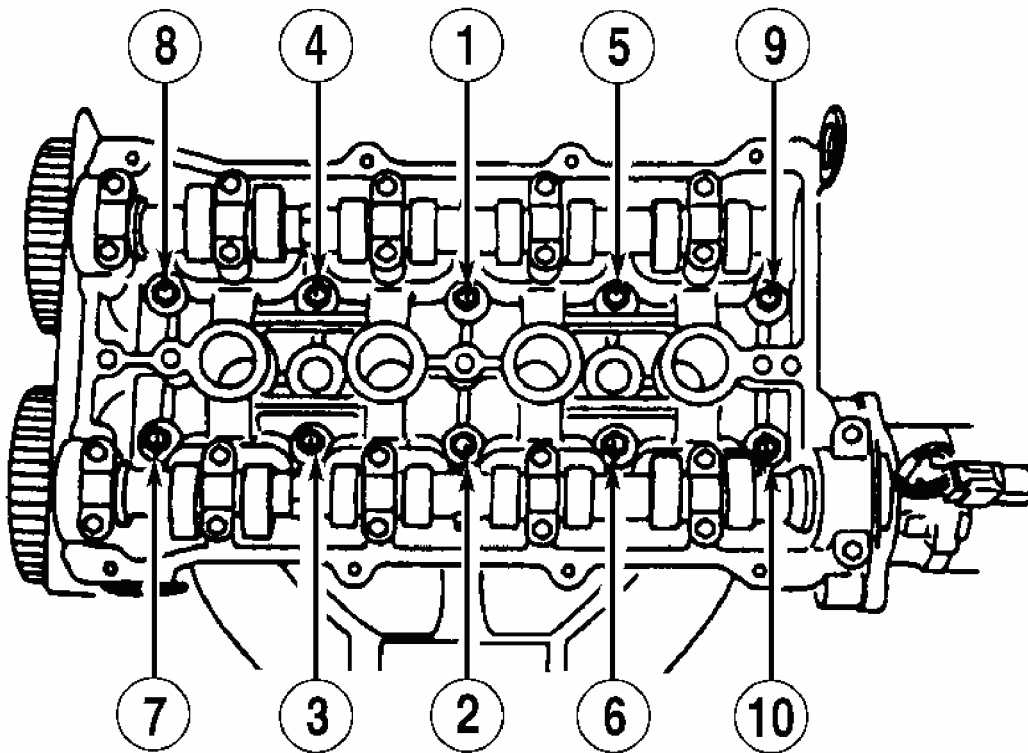

G94E47500

Fig. 5: Cylinder Head Bolt Tightening Sequence
 Courtesy of MAZDA MOTORS CORP.

CRANKSHAFT FRONT SEAL

Removal

Disconnect negative battery cable. Remove drive belts and crankshaft pulley. Remove water pump pulley, timing belt covers and timing belt. See **TIMING BELT** . Use Crankshaft Lock Tool (49-D011-102) to lock crankshaft sprocket into position. Remove crankshaft sprocket bolt. Remove crankshaft sprocket using steering wheel puller. Pry out seal.

Installation

1. Apply light oil coat to seal lip. Using a hammer and seal installer, tap seal into oil pump body until it is flush with edge of pump body. **DO NOT** bottom seal in pump body. Align keyway slots, and install crankshaft sprocket and Woodruff key with tapered side toward oil pump body. Install crankshaft sprocket bolt.
2. Using Crankshaft Lock Tool (49-D011-102), lock crankshaft sprocket into position. Tighten lock bolt to specification. See **TORQUE SPECIFICATIONS** .

1996 Mazda MX-5 Miata

1995-96 ENGINES 1.8L 4-Cylinder

3. Install timing belt. See **TIMING BELT** under REMOVAL & INSTALLATION. Install timing belt covers, pulleys and drive belts. Reconnect negative battery cable and ensure timing is correct.

TIMING BELT

NOTE: For 1995-96 vehicles, the manufacturer recommends the belt be replaced at 60,000 mile intervals for vehicles sold outside of California. For vehicles sold in California, inspect timing belt at 60,000 and 90,000 miles, and replace timing belt at 105,000 miles.

Removal

1. Disconnect negative battery cable. Drain cooling system. Remove radiator hose and bypass hoses from thermostat housing. Remove air cleaner intake duct assembly from throttle body to air cleaner filter housing.
2. Remove drive belts and water pump pulley. Align crankshaft pulley timing mark with cylinder No. 1 at TDC of compression stroke. Hold crankshaft pulley stationary. Remove crankshaft pulley bolts and pulley. Remove crankshaft pulley hub bolt and hub.
3. Remove cylinder head cover. Remove upper, center and lower timing belt cover. If timing belt is to be reused, mark timing belt rotation direction. Ensure timing marks on camshaft sprockets are aligned. See **Fig. 6** . Loosen timing belt tensioner lock bolt, and move tensioner away from belt with spring fully expanded. Remove timing belt.

Inspection

Check timing belt for cracks, peeling, abrasion or other damage. Check tensioner bearing for looseness or roughness of rotation. Inspect tensioner spring for stretching. Replace parts as necessary.

Installation

1. Position notch on crankshaft sprocket to 12 o'clock position (aligned with mark on oil pump). Align timing marks on camshaft sprockets. See **Fig. 6** . Ensure crankshaft timing mark is at TDC. Install belt around crankshaft sprocket, then working in a counterclockwise direction, route belt around camshaft sprockets.
2. Loosen timing belt tensioner lock bolt and allow spring to apply tension on belt. Snug tensioner lock bolt. Rotate crankshaft 2 complete turns in direction of normal engine rotation. Ensure timing marks align. If timing marks are not aligned, remove belt, realign all timing marks, and repeat installation procedure.
3. Check timing belt deflection with 22 lbs. (10 kg) of pressure applied to belt. See **Fig. 7** . Ensure timing belt deflection is within specification. See **TIMING BELT DEFLECTION** .

1996 Mazda MX-5 Miata

1995-96 ENGINES 1.8L 4-Cylinder

TIMING BELT DEFLECTION

Application	(1) Deflection In. (mm)
Miata	.35-.45 (9.0-11.5)

(1) Deflection measurement is with 22 lbs. (10 kg) of pressure applied to timing belt.
See **Fig. 7**.

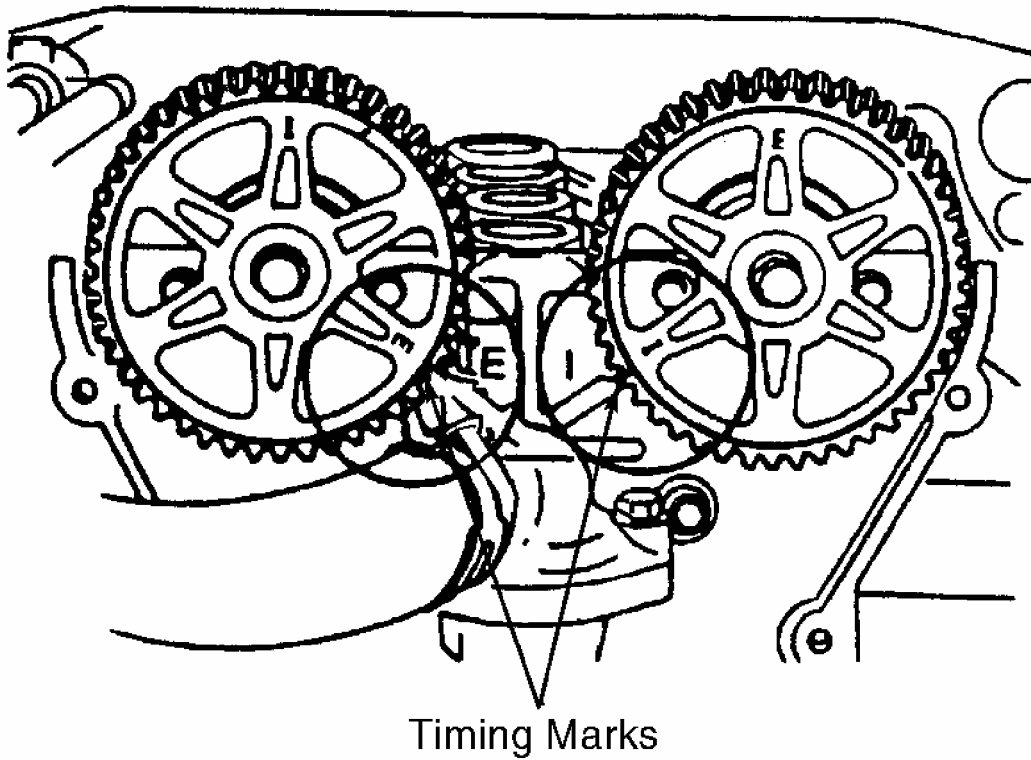

93H84142

Courtesy of Mazda Motors Corp.

Fig. 6: Aligning Camshaft Timing Marks
Courtesy of MAZDA MOTORS CORP.

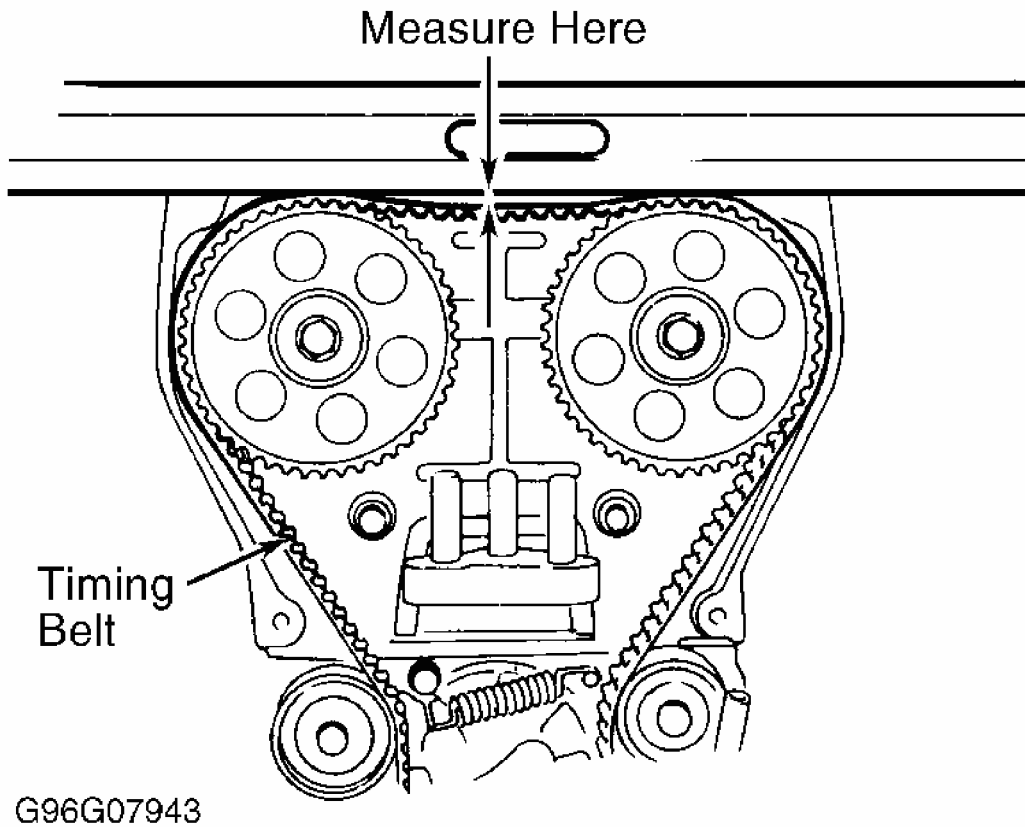

Fig. 7: Measuring Timing Belt Deflection
Courtesy of MAZDA MOTORS CORP.

HYDRAULIC LASH ADJUSTER (HLA)

NOTE: If hydraulic lash adjusters are persistently noisy, check with manufacturer for availability of modified adjusters.

Removal

Disconnect negative battery cable. Remove camshaft. See **CAMSHAFT**. Mark location of each HLA for reassembly reference. Remove HLA from cylinder head.

Inspection

Place HLA in palm of hand. Attempt to compress HLA plunger with thumb. If plunger compresses, replace HLA.

Installation

Insert HLA in original location. To complete installation, reverse removal procedure.

1996 Mazda MX-5 Miata

1995-96 ENGINES 1.8L 4-Cylinder

Tighten camshaft bearing caps evenly in sequence to specification. See **Fig. 8** . See **TORQUE SPECIFICATIONS** .

CAMSHAFT

NOTE: Exhaust camshaft has a slot for camshaft position sensor drive. Match mark camshafts and sprockets for installation reference.

Removal

Remove cylinder head cover. Remove timing belt. See **TIMING BELT** . Remove distributor/camshaft position sensor. Reference mark camshafts, caps and sprockets, and remove sprockets. Loosen camshaft bearing cap bolts evenly in 5-6 steps, in sequence. See **Fig. 8** . Remove camshafts.

Inspection

Check camshaft end play. Check camshaft journal diameters and bearing clearances. Check camshaft lobes for wear. See **CAMSHAFT** under ENGINE SPECIFICATIONS. If any measurement is not within specification, replace camshaft and/or cylinder head.

Installation

To install, reverse removal procedure. On both camshafts, apply small amount of silicone sealant to contact area of cylinder head/camshaft seal cover cap. Tighten camshaft bearing cap bolts evenly in sequence to specification. See **Fig. 8** . See **TORQUE SPECIFICATIONS** .

1996 Mazda MX-5 Miata

1995-96 ENGINES 1.8L 4-Cylinder

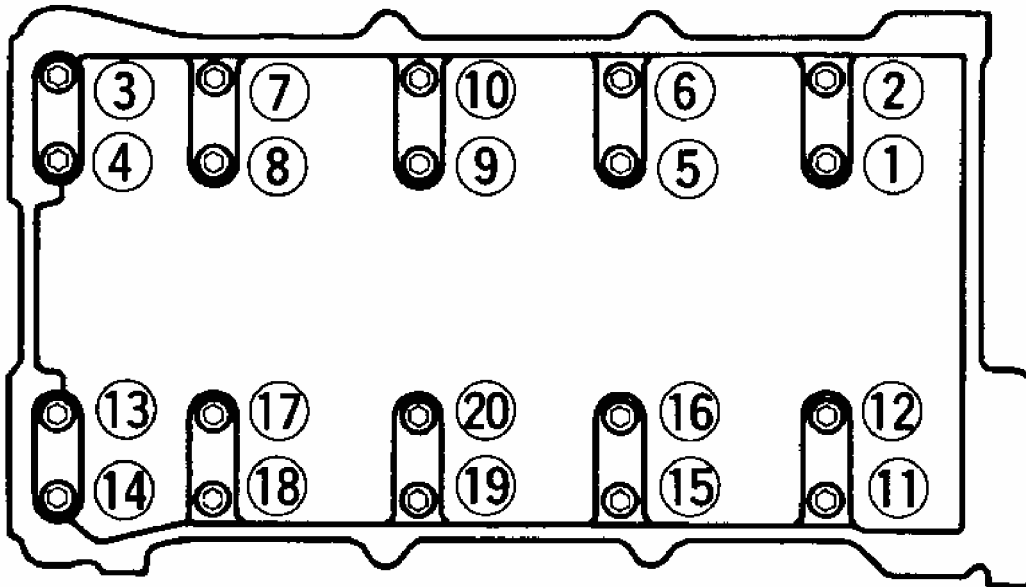

96I07944

Fig. 8: Camshaft Bearing Cap Bolt Removal & Installation Sequence Removal
Courtesy of MAZDA MOTORS CORP.

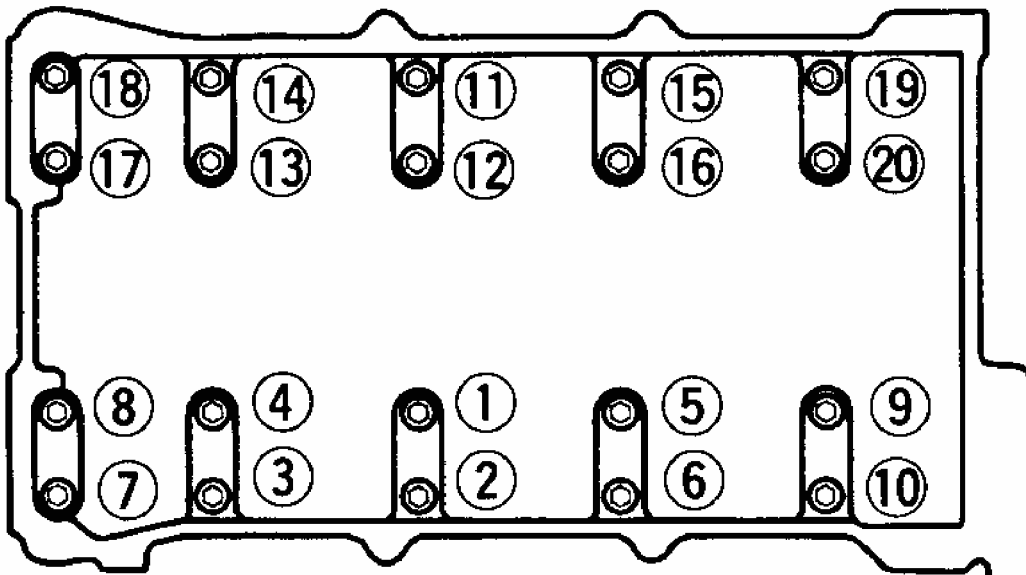

96B07945

Fig. 9: Camshaft Bearing Cap Bolt Removal & Installation Sequence Installation

Courtesy of MAZDA MOTORS CORP.**CRANKSHAFT REAR OIL SEAL****Removal & Installation**

1. Disconnect negative battery cable. Remove transmission/transaxle and flywheel. For removal procedure, see TRANSMISSION REMOVAL & INSTALLATION - A/T article in AUTOMATIC TRANS SERVICE section or TRANSMISSION REMOVAL & INSTALLATION - M/T article in MANUAL TRANS SERVICE section.
2. To install, apply light coat of oil to seal lip and push seal over crankshaft. Tap seal into rear cover until it is flush with edge of rear cover. DO NOT bottom seal in cover.
3. Completely remove used sealant from flywheel bolts. Apply lock-type sealant to bolts and install flywheel to crankshaft. Tighten bolts to 71-76 ft. lbs. (96-103 N.m) in a star-pattern sequence. Install clutch assembly (if equipped) and tighten cover bolts to 13-20 ft. lbs. (18-26 N.m) in a star-pattern sequence. Install transmission/transaxle. See TRANSMISSION REMOVAL & INSTALLATION - A/T article in AUTOMATIC TRANS SERVICE section or TRANSMISSION REMOVAL & INSTALLATION - M/T article in MANUAL TRANS SERVICE section.

WATER PUMP**Removal & Installation**

1. Drain engine coolant. Disconnect battery cable. Position No. 1 cylinder at TDC of compression stroke.
2. Remove air cleaner intake duct between throttle body and air cleaner/filter assembly. Remove upper radiator hose and by-pass hoses from thermostat housing.
3. Remove drive belts and water pump pulley. Remove power steering pump with hoses attached and secure pump away from engine (if necessary). Remove timing belt, tensioner and idler. See **TIMING BELT**.
4. Unbolt water inlet pipe from water pump. Water pump inlet pipe has lower radiator hose and by-pass pipe attached to it. Remove bolts from water pump. To install, reverse removal procedure. Tighten bolt to specification. See [TORQUE SPECIFICATIONS](#).

NOTE: For further information on cooling systems, see **COOLING SYSTEM SPECIFICATIONS & ELECTRIC COOLING FANS** article in **ENGINE COOLING** section.

OIL PAN

NOTE: Engine must be supported in order to remove oil pan.

Removal & Installation

1996 Mazda MX-5 Miata

1995-96 ENGINES 1.8L 4-Cylinder

1. Disconnect negative battery cable. Drain engine oil. Remove dipstick, tube and "O" ring. Raise vehicle on hoist. Remove engine undercover. Disconnect steering column shaft at steering rack coupling. See **Fig. 10** . Remove engine mount nuts. Lift and support engine using jack.
2. Support crossmember using transmission jack and remove crossmember bolts. Slowly and carefully lower crossmember until clearance between oil pan and steering rack is about 4 inches. Remove oil pan bolts from engine block and transmission.
3. DO NOT damage sealant contact surfaces. Remove oil pan by prying between oil pan and transmission support. Remove oil pan baffle by prying it from engine. See **Fig. 10** . DO NOT deform oil pan baffle. Replace oil pan baffle if deformed. Clean sealant from oil pan, bolts, engine block and both sides of oil pan baffle.
4. To install, apply oil resistant sealant to engine block and oil pan. Install oil pan baffle and oil pan within 5 minutes of applying sealant. To complete installation, reverse removal procedure. Tighten bolts to specification. See **TORQUE SPECIFICATIONS** . Fill engine with oil to specification. See **ENGINE LUBRICATION SYSTEM** under ENGINE OILING.

1996 Mazda MX-5 Miata

1995-96 ENGINES 1.8L 4-Cylinder

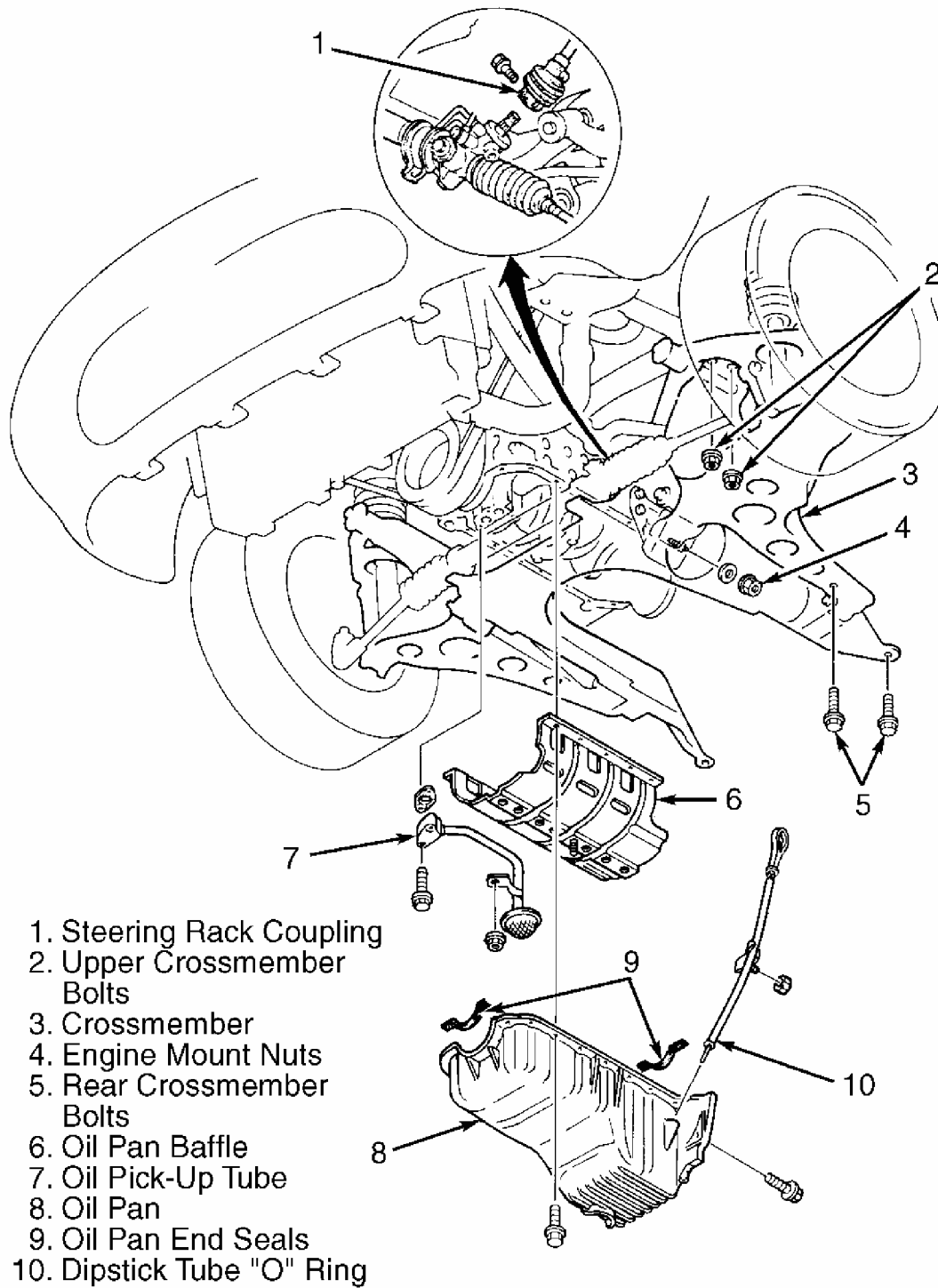

G91D01845

Fig. 10: Removing Crossmember & Oil Pan
Courtesy of MAZDA MOTORS CORP.

OVERHAUL

CYLINDER HEAD

Cylinder Head

Clean carbon and gasket material from all mating surfaces. Using a tap, clean cylinder head threads. Check cylinder head warpage. If warpage exceeds specification, resurface head, but **DO NOT** exceed grinding limit. See **CYLINDER HEAD** under ENGINE SPECIFICATIONS. After resurfacing cylinder head, check cylinder head height. Replace cylinder head if height is less than minimum specification.

Valve Springs

Ensure valve spring free length, out-of-square and compressed length are within specification. See **VALVES & VALVE SPRINGS** under ENGINE SPECIFICATIONS. Replace valve spring if necessary.

NOTE: Intake and exhaust valve stem seals are different. Exhaust seals can be identified by ridges molded into top of seal. Intake seals do not have identifying ridges. Incorrect installation of valve stem seals will cause premature failure.

Valve Stem Oil Seals

1. Use Installer Set (49-L012-0A0) to install valve seals. See **Fig. 11** . Adjust installer dimension "L" to seal depth of .720-.744" (18.3-18.9 mm). Using hand pressure **ONLY**, install seal until it contacts cylinder head. Lightly oil valve seal lip.

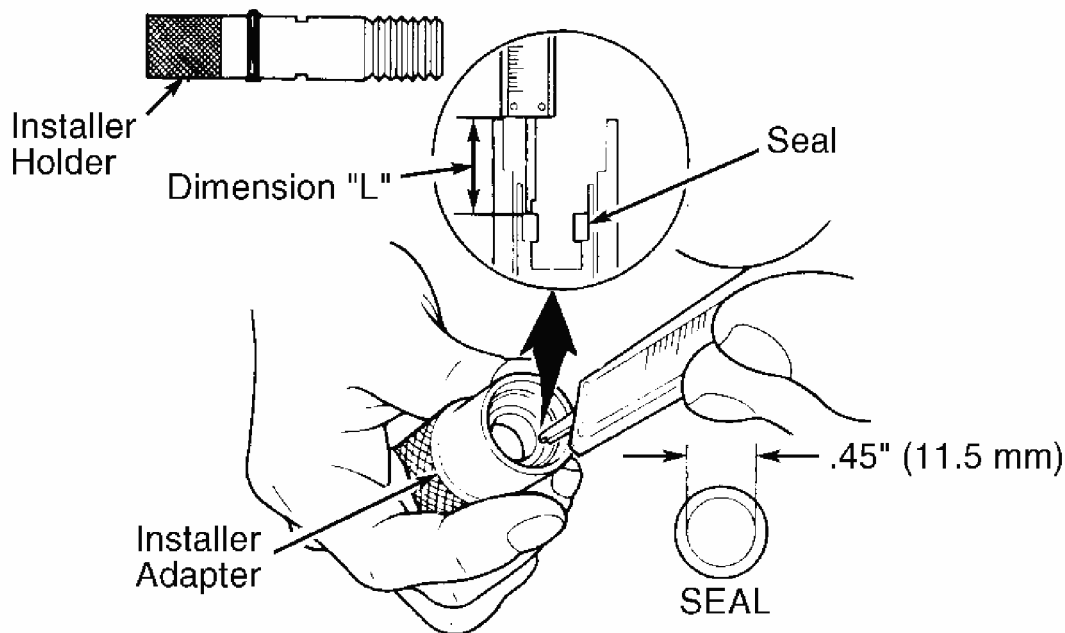

G94D47509

Fig. 11: Installing Valve Guide Seals
 Courtesy of MAZDA MOTORS CORP.

NOTE: Use only **NEW** exhaust valve guides to replace intake or exhaust valve guides.

Valve Guides

1. Check valve stem-to-valve guide oil clearance. Ensure valve guide inside diameter is within specification. See **CYLINDER HEAD** under ENGINE SPECIFICATIONS.
2. Completely disassemble cylinder head. Gradually heat cylinder head in water to 194°F (94°C). Using Valve Guide Remover (49-B012-005), drive valve guide out, working from combustion chamber side of cylinder head. Repeat procedure if required, keeping cylinder head hot so aluminum head will not warp.
3. If required, install new circlip on guide. Using proper components of Valve Guide Installer (49-L012-0A0), adjust installer guide depth (dimension "L") to specification using depth micrometer or caliper. See **VALVE GUIDE INSTALLED HEIGHT** . See **Fig. 12** .
4. Insert guide into pre-adjusted installer and drive guide into cylinder head from camshaft side until guide circlip, and/or installer contact cylinder head. Measure dimension "L" (guide installed height). See **Fig. 13** . If installed height is not within specification, adjust or replace valve guide or cylinder head as necessary. See **VALVE GUIDE INSTALLED HEIGHT** .

1996 Mazda MX-5 Miata

1995-96 ENGINES 1.8L 4-Cylinder

VALVE GUIDE INSTALLED HEIGHT

Application	In. (mm)
Miata	.720-.744 (18.30-18.90)

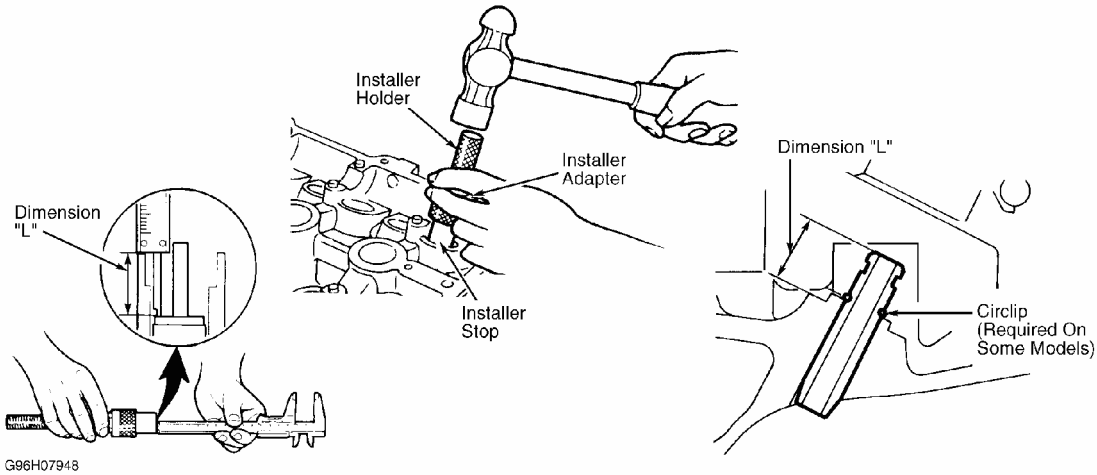
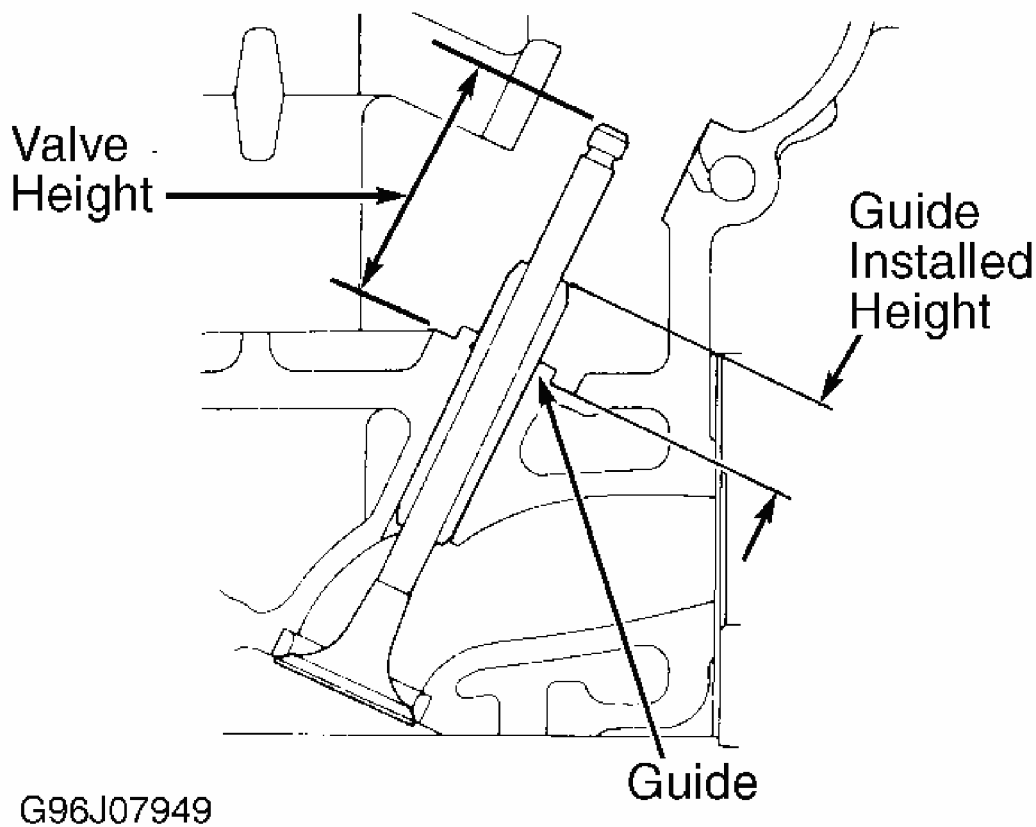

Fig. 12: Adjusting Valve Guide Installer & Installing Guide
Courtesy of MAZDA MOTORS CORP.



G96J07949

Fig. 13: Measuring Installed Valve & Guide Height
 Courtesy of MAZDA MOTORS CORP.

Valve Seat

1. Service valve guide before valve seat. Valve seat replacement information is not available at time of publication. Inspect valve seat for roughness and damage. Check valve seat angle and seat width.
2. Measure seat contact width on valve and ensure seat contact position is in center of valve face. Service seat if angle and width are not within specification. See **CYLINDER HEAD** under ENGINE SPECIFICATIONS. Measure valve installed height after servicing valve seat. See **Fig. 13** . See **VALVE INSTALLED HEIGHT** .
3. If valve installed height is within serviceable range, install adjusting shim on spring seat. If installed height exceeds serviceable range, replace cylinder head.

VALVE INSTALLED HEIGHT

Application	In. (mm)
Normal	1.772-1.791 (45.00-45.50)

1996 Mazda MX-5 Miata

1995-96 ENGINES 1.8L 4-Cylinder

Serviceable

1.733-1.772 (45.60-46.50)

Valves

Check valve face angle, head diameter, margin thickness and stem diameter. Service or replace valves if measurements are not within specifications. See **VALVES & VALVE SPRINGS** under ENGINE SPECIFICATIONS.

Valve Seat Correction Angles

Measure seat contact width on valve. See VALVE SEAT. If seat width is not within specification or if valve face does not contact center of valve seat, correct seat using a 70-degree grinding stone. After correcting seat, lightly finish seat with 45-degree grinding stone.

VALVE TRAIN

Hydraulic Lash Adjusters

1. Remove camshaft cover. Check movement of each Hydraulic Lash Adjuster (HLA) by pushing downward using hand pressure only. If HLA compresses, replace HLA. To remove HLA, remove camshafts. See **CAMSHAFT** under REMOVAL & INSTALLATION. Mark location of HLA before removing from bore. Lift HLA from cylinder head.

NOTE: If hydraulic lash adjusters are persistently noisy, check with manufacturer for availability of modified adjusters.

2. Inspect HLA friction surfaces for wear and damage. Replace HLA if required. Coat HLA with engine oil and install in original location. Ensure HLA moves smoothly in bore by using small magnet attached to HLA.

CYLINDER BLOCK ASSEMBLY

NOTE: During disassembly, match mark components for reassembly reference.

Piston & Connecting Rod Assembly

1. Before removing rod cap from crankshaft, measure and record rod side play. See **CONNECTING RODS** under ENGINE SPECIFICATIONS. Before removing connecting rods, measure and record connecting rod bearing oil clearance. See **CRANKSHAFT, MAIN & CONNECTING ROD BEARINGS** under ENGINE SPECIFICATIONS.
2. Before separating piston from connecting rod, mark piston in relation to connecting

rod. Check oscillation movement of piston and rod assembly (hold piston horizontally, lift rod and allow rod to drop by its own weight). If pin binds in pin bore (rod does not drop), replace piston and/or pin as necessary.

3. To separate components, press piston pin out of piston and rod assembly, noting pressure required to remove piston pin. If piston pin can be pressed out with less than 1100 lbs. (500 kg) of pressure, replace piston and/or connecting rod.
4. Ensure piston pin diameter, piston fit and rod fit are within specification. See **PISTONS, PINS & RINGS** under ENGINE SPECIFICATIONS. Using 1100-3300 lbs. (500-1500 kg) of pressure, install piston pin through side of piston that has an "F" mark near pin bore. See **Fig. 14** . Install piston and rod assembly so "F" mark on side of piston is facing front of engine.

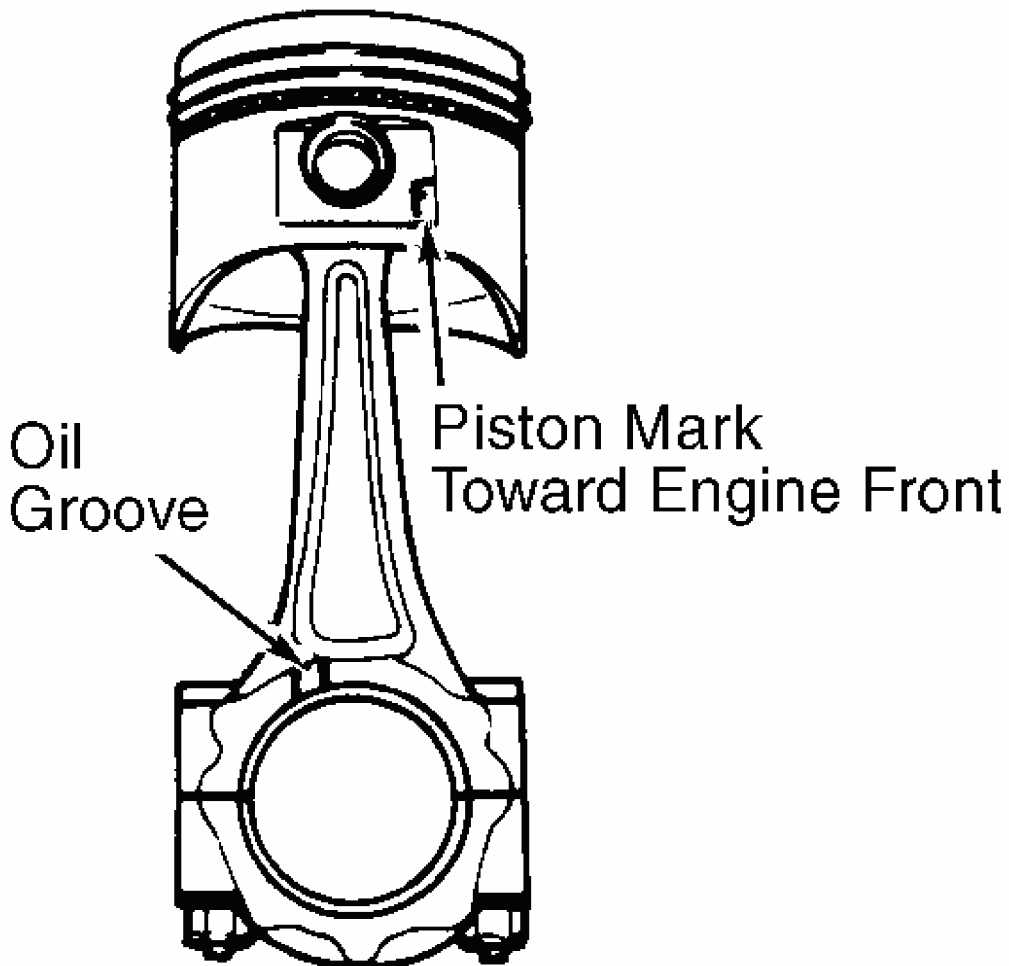

G96B07950

Fig. 14: Installing Piston & Connecting Rod Assembly
Courtesy of MAZDA MOTORS CORP.

Fitting Pistons

1. Ensure pistons are not scored or damaged. Measure piston diameter on piston skirt at 90-degree angle from piston pin, .65" (16.5 mm) below lowest ring groove. See **PISTONS, PINS & RINGS** under ENGINE SPECIFICATIONS.
2. Check piston-to-cylinder wall clearance in 3 different vertical places of piston travel. If clearance is not within specification, re-bore cylinders to fit oversize pistons. Using NEW piston rings, measure piston ring side clearance around entire piston circumference. If clearance is not within specification, replace piston. See **PISTONS, PINS & RINGS** .

NOTE: Pistons and rings are available in .010" (.25 mm) and .020" (.50 mm) oversize.

Piston Rings

1. If ring end gap and side clearance are not within specification, replace piston and/or rings as necessary. See **PISTONS, PINS & RINGS** under ENGINE SPECIFICATIONS.
2. Install oil ring spacer. Ensure ends DO NOT overlap. See **Fig. 15** . Upper and lower rails are the same and are interchangeable. In stall rails, ensuring rails are expanded by spacer tangs (oil rings when assembled should rotate freely). Install rings No. 1 (top) and No. 2 (second) with "R" mark toward top of piston. Ensure ring end gaps are properly positioned around piston. See **Fig. 16** .

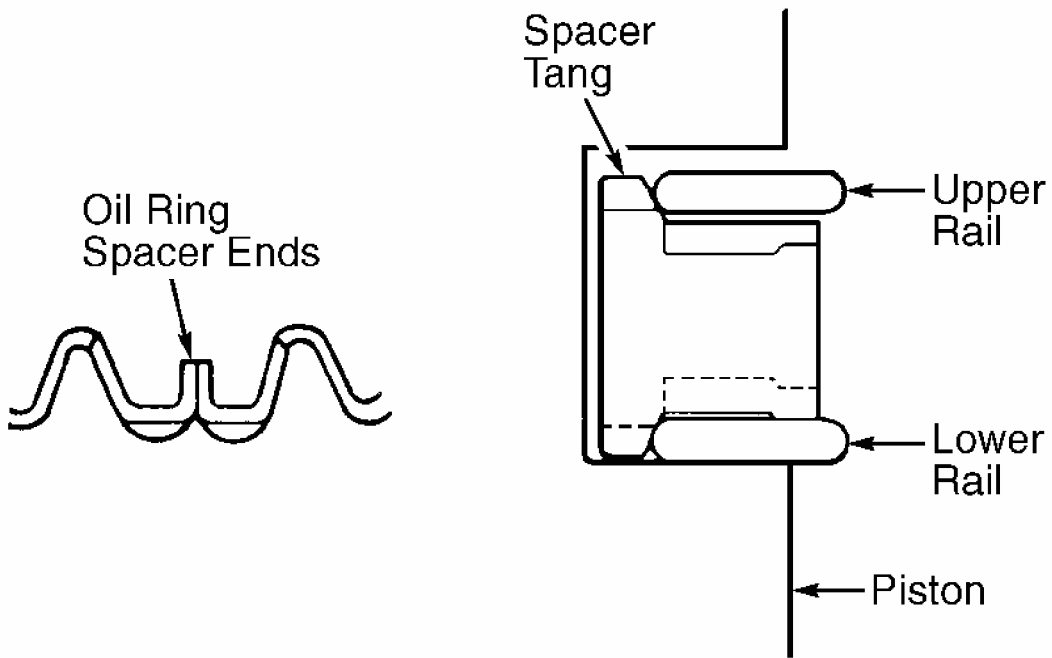

G93E84511

Fig. 15: Identifying Oil Rings
Courtesy of MAZDA MOTORS CORP.

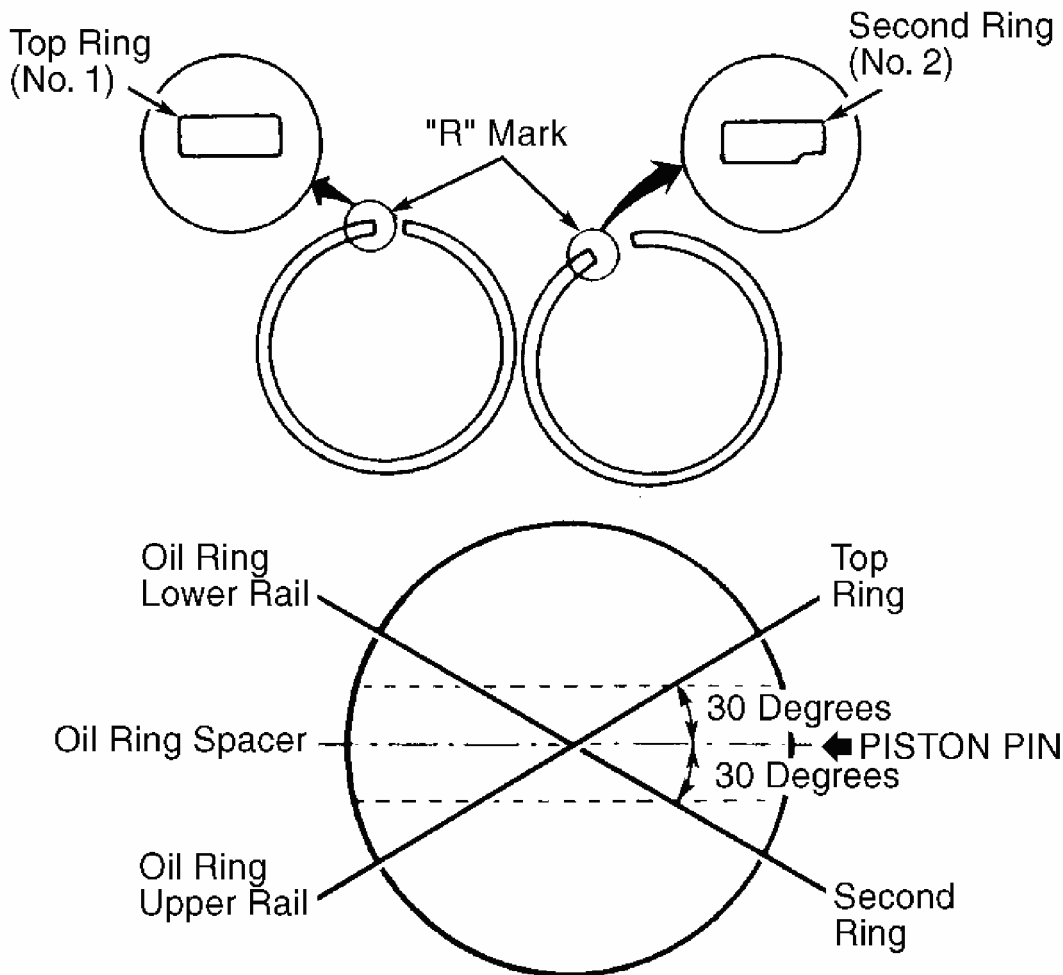

G93F84512

Fig. 16: Identifying Piston Rings & Positioning Ring End Gaps
 Courtesy of MAZDA MOTORS CORP.

Crankshaft & Main Bearings

1. Check crankshaft connecting rod journals for wear, out-of-round, taper and undersize. Machine or replace crankshaft and/or bearings as necessary. See **CRANKSHAFT, MAIN & CONNECTING ROD BEARINGS** under ENGINE SPECIFICATIONS.
2. Before removing main cap, measure and record crankshaft end play by prying crankshaft forward, then rearward. Using Plastigage method, measure and record main bearing oil clearance. Remove crankshaft. Measure and record each main journal diameter in 2 places. See **CRANKSHAFT, MAIN & CONNECTING ROD BEARINGS** under ENGINE SPECIFICATIONS.
3. Install main bearing caps with square mark facing front of engine. Tighten main bearing cap bolts in 2-3 step, working outward from center bearing. Tighten bolts to specification. See **TORQUE SPECIFICATIONS**.

1996 Mazda MX-5 Miata

1995-96 ENGINES 1.8L 4-Cylinder

Thrust Bearing

Install thrust bearing before installing crankshaft. Check crankshaft end play with crankshaft bearings and caps installed, but without connecting rods attached to crankshaft. DO NOT turn crankshaft until bearings are lubricated. If crankshaft end play exceeds specification, grind crankshaft and replace thrust bearings with oversize thrust bearings, or replace crankshaft and thrust bearings. See **CRANKSHAFT, MAIN & CONNECTING ROD BEARINGS** under ENGINE SPECIFICATIONS.

Cylinder Block

Check cylinder bore out-of-round, taper, ridge and piston-to-cylinder bore clearance. Check head gasket surface for warpage. If warpage is not within specification, machine or replace cylinder block as necessary. See **CYLINDER BLOCK** under ENGINE SPECIFICATIONS. Remove, clean and install oil jets for piston oil spraying.

ENGINE OILING

ENGINE LUBRICATION SYSTEM

NOTE: See cross-sectional view of engine oil circuit. See **Fig. 17** .

1996 Mazda MX-5 Miata

1995-96 ENGINES 1.8L 4-Cylinder

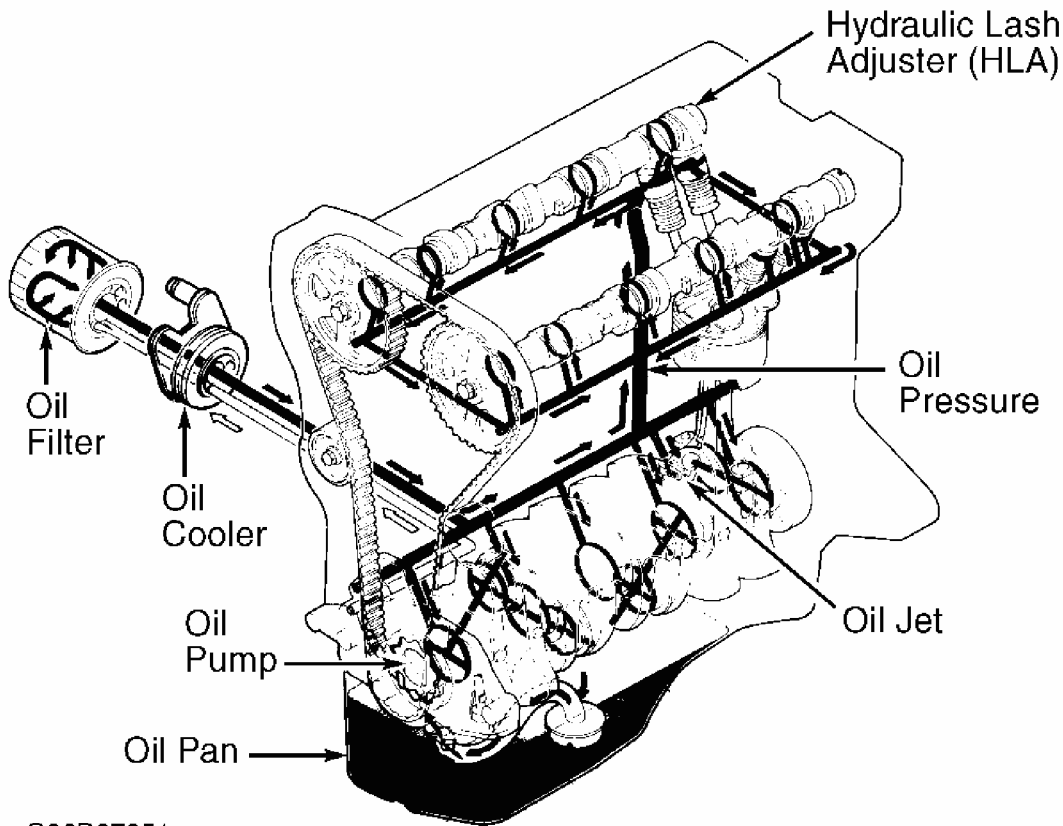

G96D07951

Fig. 17: Cross-Sectional View Of Engine Oil Circuit
Courtesy of MAZDA MOTORS CORP.

Crankcase Capacity

See **ENGINE OIL CRANKCASE CAPACITY** .

Oil Pressure

With engine at operating temperature, oil pressure should be 15-28 psi (1.0-2.0 kg/cm²) at 1000 RPM, and 43-57 psi(3.0-4.0 kg/cm²) at 3000 RPM.

Oil Pressure Relief Valve

Pressure relief valve opening pressure is 50-64 psi (3.5-4.5 kg/cm²). Pressure relief valve is located in oil pump body and is not adjustable.

ENGINE OIL CRANKCASE CAPACITY

Application	W/O Filter Qts. (L)	W/Filter Qts. (L)
Miata	3.8 (3.6)	4.0 (3.8)

1996 Mazda MX-5 Miata

1995-96 ENGINES 1.8L 4-Cylinder

OIL PUMP

Removal & Disassembly

1. Disconnect negative battery cable. Remove dipstick, tube and "O" ring. Drain engine oil and coolant. Remove drive belts, crankshaft and water pump pulleys. Remove generator, A/C compressor and mounting bracket. Without disconnecting A/C hoses, secure A/C compressor away from engine. Remove timing belt and related components. See **TIMING BELT** under REMOVAL & INSTALLATION.
2. Hold crankshaft sprocket in place and remove crankshaft sprocket bolt. Remove crankshaft sprocket using steering wheel puller. Leave crankshaft Woodruff key in place.
3. Remove oil pan and oil pump pick-up tube. See **OIL PAN** under REMOVAL & INSTALLATION. Remove oil pump housing assembly. Using a screwdriver protected with a rag, drive oil seal out from inside of oil pump housing assembly.
4. Remove pump cover screws (use a manual impact screwdriver, if necessary). See **Fig. 18** . Remove pump cover. Note location of alignment marks on inner and outer rotors. Remove inner and outer rotors. To remove pressure relief valve, remove spring seat, pressure spring and control plunger.

Inspection

Replace pressure relief valve spring if length is not as specified. See **OIL PUMP SPECIFICATIONS** . Ensure plunger slides freely in bore. Replace oil pump housing assembly if clearances are not as specified. See **OIL PUMP SPECIFICATIONS** .

Reassembly & Installation

1. Apply oil to friction surfaces. Install inner and outer rotors with marks aligned. See **Fig. 19** . Install pressure relief valve components. Apply oil to lip of NEW oil seal. Press oil seal into bore until even with face of oil pump housing assembly.
2. Install pump cover. Tighten screws to 53-78 INCH lbs. (6-9 N.m). To complete installation, reverse removal procedure. Tighten bolts to specification. See **TORQUE SPECIFICATIONS** .

OIL PUMP SPECIFICATIONS

Application	Maximum Clearance In. (mm)
Maximum Rotor Tip Clearance ⁽¹⁾	.0079 (.20)
Maximum Rotor-To-Pump Body Clearance ⁽²⁾	.0079 (.20)
Maximum Rotor Side Clearance ⁽³⁾	.0055 (.14)
Pressure Relief Spring Free Length	1.809 (45.94)

(1) See **Fig. 19** .

- (2) Insert feeler gauge between outer rotor and pump body.
- (3) Place straightedge across pump body and check clearance between straightedge and both rotors.

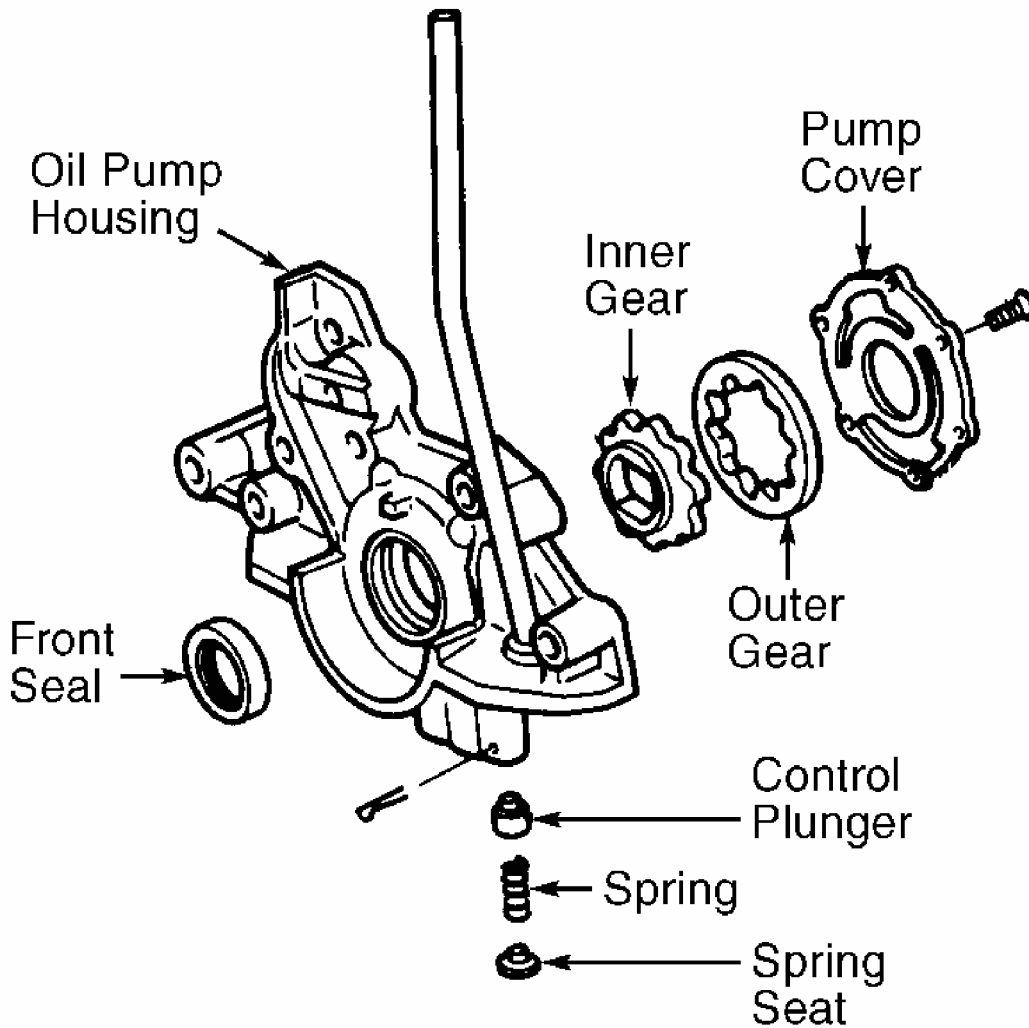

G96F07952

Fig. 18: Exploded View Of Oil Pump
Courtesy of MAZDA MOTORS CORP.

1996 Mazda MX-5 Miata

1995-96 ENGINES 1.8L 4-Cylinder

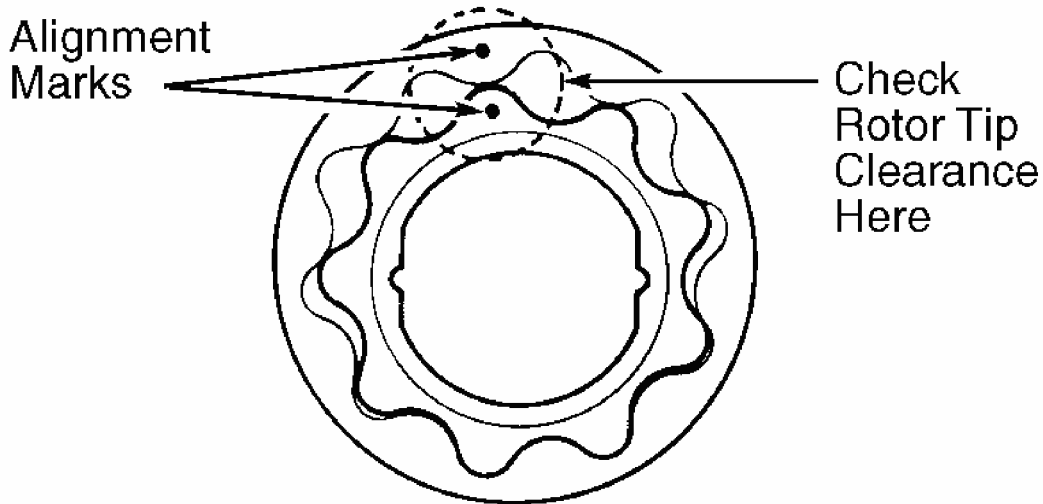

G93I84515

Fig. 19: Aligning Marks On Inner & Outer Rotor
Courtesy of MAZDA MOTORS CORP.

TORQUE SPECIFICATIONS

TORQUE SPECIFICATIONS

Application	Ft. Lbs. (N.m)
Camshaft Sprocket Bolt	36-45 (49-61)
Compressor Bracket-To-Engine Bolt	28-38 (38-51)
Connecting Rod Cap Nut	35-37 (48-50)
Crankshaft Pulley Bolts	9-13 (12-18)
Crankshaft/Timing Belt Sprocket Bolt	116-123 (157-167)
Crossmember-To-Frame Bolt	47-66 (63-89)
Cylinder Head Bolt ⁽³⁾	56-60 (76-81)
Distributor Bolt	14-19 (19-26)
Drive Shaft Bolts	37-43 (50-58)
Engine Mount Nut	42-58 (57-79)
Engine Mount-To-Engine Bolt	27-40 (37-54)
Engine Mount-To-Frame Nut	42-57 (57-77)
Exhaust Header Pipe-To-Exhaust Manifold Nut	23-34 (31-46)
Exhaust Manifold Nut	⁽¹⁾ 28-34 (38-46)
Flywheel Bolt	71-76 (96-103)
Fuel Rail Bolt	14-19 (19-26)

1996 Mazda MX-5 Miata

1995-96 ENGINES 1.8L 4-Cylinder

Generator Top Bolt	27-38 (37-51)
Intake Manifold Bolt/Nut	(1) 14-19 (19-26)
Intake Manifold Support Bracket	14-18 (19-25)
Main Bearing Cap Bolt	
Step 1	(1) 22-27 (30-37)
Step 2 (Final)	(1) 40-43 (54-58)
Oil Pan-To-Transmission Bolt	48-65 (64-88)
Oil Pump-To-Block Bolt	14-19 (19-26)
Power Steering Pump-To-Bracket Bolt	28-38 (38-51)
PPF/Differential Spacer Mounting Bolt (2)	27-38 (37-51)
PPF-To-Differential Long Mounting Bolt (2)	77-91 (104-123)
PPF-To-Transmission Side Mounting Bolt (2)	77-91 (104-123)
PPF/Transmission Rear Bracket Mounting Bolt (2)	27-40 (37-54)
Spark Plug	11-16 (15-22)
Timing Belt Tensioner Bolt	27-38 (37-51)
Water Pump Bolt	14-19 (19-26)
INCH Lbs. (N.m)	
Camshaft Bearing Cap Bolt	(2) 100-125 (11.3-14.1)
Cylinder Head Cover Bolt (3)	43-78 (5-9)
Oil Jet	104-156 (12-18)
Oil Pan-To-Engine Block Bolt	70-95 (8-11)
Oil Pump Cover Screws	53-78 (6-9)
Oil Strainer Bolt	70-95 (8-11)
Rear Cover Bolt	70-95 (8-11)
Water Pump Pulley Bolt	70-95 (8-11)

(1) Tighten evenly to specification in alternating sequence.

(2) Tighten in sequence. See **Fig. 8** .

(3) Tighten in sequence. See **Fig. 5** .

ENGINE SPECIFICATIONS**GENERAL ENGINE SPECIFICATIONS****GENERAL ENGINE SPECIFICATIONS**

Application	Specification

1996 Mazda MX-5 Miata

1995-96 ENGINES 1.8L 4-Cylinder

Displacement	112.2 Cu. In. (1.8L)
Bore	3.27" (83.0 mm)
Stroke	3.35" (85.0 mm)
Compression Ratio	9.0:1
Fuel System	PFI
Horsepower @ RPM	128 @ 6500
Torque Ft. Lbs. @ RPM	110 @ 5000

CRANKSHAFT, MAIN & CONNECTING ROD BEARINGS SPECIFICATIONS**CRANKSHAFT, MAIN & CONNECTING ROD BEARINGS**

Application	In. (mm)
Crankshaft	
End Play	
Standard	.0032-.0111 (.080-.282)
Maximum	.0118 (.30)
Maximum Runout	.0016 (.04)
Main Bearings	
Journal Diameter	
Standard Bearings	1.9661-1.9667 (49.938-49.956)
Journal Out-Of-Round	.002 (.05)
Oil Clearance	
Standard	.0008-.0014 (.020-.036)
Maximum	.004 (.10)
Connecting Rod Bearings	
Journal Diameter	
Standard Bearings	1.7693-1.7699 (44.940-44.956)
Journal Out-Of-Round	.002 (.05)
Oil Clearance	
Standard	.0008-.0027 (.020-.068)
Maximum	.0039 (.100)

CONNECTING RODS SPECIFICATIONS**CONNECTING RODS**

--	--

1996 Mazda MX-5 Miata

1995-96 ENGINES 1.8L 4-Cylinder

Application	In. (mm)
Bore Diameter	
Crankpin Bore	1.8898-1.8904 (48.000-48.016)
Pin Bore	.7876-.7879 (20.003- 20.014)
Center-To-Center Length	5.231-5.234 (132.85- 132.95)
Maximum Bend	(1)
Side Play	
Standard	.0044-.0103 (.110- .262)
Maximum	.012 (.30)
(1) Bend must not exceed .003" per 1.97" (.075 mm per 50 mm).	

PISTONS, PINS & RINGS SPECIFICATIONS**PISTONS, PINS & RINGS**

Application	In. (mm)
Pistons	
Clearance	
Standard	.0013-.0023 (.032- .059)
Maximum	.006 (.15)
Diameter	
Standard	3.2660-3.2666 (82.954-82.974)
Oversize	
.010" (0.25 mm)	3.2761-3.2762 (83.211-83.217)
.020" (0.50 mm)	3.2859-3.2860 (83.461-83.467)
Pins	
Diameter	.7869-.7871 (19.987- 19.993)
Piston Fit	-.0002-.0005 (-.005-.013)
Rings	
No. 1	
End Gap	

1996 Mazda MX-5 Miata

1995-96 ENGINES 1.8L 4-Cylinder

Standard	.006-.011 (.15-.30)
Maximum	.039 (1.0)
Side Clearance	
Standard	.0012-.0025 (.030-.065)
Maximum	.006 (.15)
No. 2	
End Gap	
Standard	.006-.011 (.15-.30)
Maximum	.039 (1.0)
Side Clearance	
Standard	.0012-.0027 (.030-.070)
Maximum	.006 (.15)
No. 3 (Oil)	
End Gap	
Standard	.008-.027 (.20-.70)
Maximum	.039 (1.0)

CYLINDER BLOCK SPECIFICATIONS**CYLINDER BLOCK**

Application	In. (mm)
Cylinder Bore	
Standard	3.2678-3.2684 (83.000-83.019)
Oversize	
.010" (0.25 mm)	3.2778-3.2780 (83.256-83.263)
.020" (0.50 mm)	3.2877-3.2879 (83.506-83.513)
Maximum Taper & Out-Of-Round	.0007 (.019)
Minimum Deck Height ⁽¹⁾	8.720 (221.5)
Maximum Deck Warpage	.006 (.15)

(1) DO NOT machine more than .008" (.20 mm) from cylinder block deck surface.

CYLINDER HEAD SPECIFICATIONS**CYLINDER HEAD**

--	--

1996 Mazda MX-5 Miata

1995-96 ENGINES 1.8L 4-Cylinder

Application	Specification
Cylinder Head	
Height	5.268-5.275" (133.8-134.0 mm)
Grinding Limit	.004" (.10 mm)
Maximum Warp	.004" (.10 mm)
Valve Seats	
Intake Valve	
Seat Angle	45°
Seat Width	.032-.055" (0.80-1.40 mm)
Exhaust Valve	
Seat Angle	45°
Seat Width	.032-.055" (0.80-1.40 mm)
Valve Guides	
Intake Valve	
Valve Guide I.D.	.2367-.2374" (6.01-6.03 mm)
Valve Guide Installed Height	.721-.744" (18.3-18.9 mm)
Valve Stem-To-Guide Oil Clearance	
Standard	.0010-.0023" (.025-.060 mm)
Maximum	.008" (.20 mm)
Exhaust Valve	
Valve Guide I.D.	.2367-.2374" (6.01-6.03 mm)
Valve Guide Installed Height	.721-.744" (18.3-18.9 mm)
Valve Stem-To-Guide Oil Clearance	
Standard	.0012-.0025" (.030-.065 mm)
Maximum	.008" (.20 mm)

VALVES & VALVE SPRINGS SPECIFICATIONS**VALVES & VALVE SPRINGS**

Application	Specification
Valves	

1996 Mazda MX-5 Miata

1995-96 ENGINES 1.8L 4-Cylinder

Face Angle	45°
Installed Height	
Normal	1.772-1.791" (45.00-45.50 mm)
Serviceable	1.733-1.772" (45.60-46.50 mm)
Minimum Margin	
Intake	.035" (0.9 mm)
Exhaust	.039" (1.0 mm)
Refinish Length	
Intake	
Standard	4.0114" (101.89 mm)
Minimum	3.9524" (100.39 mm)
Exhaust	
Standard	4.0153" (101.99 mm)
Minimum	3.9563" (100.49 mm)
Stem Diameter	
Intake	
Standard	.2351-.2356" (5.970-5.985 mm)
Minimum	.2331" (5.920 mm)
Exhaust	
Standard	.2349-.2354" (5.965-5.980 mm)
Minimum	.2329" (5.915 mm)
Valve Springs	
Free Length	1.821" (46.26 mm)
Maximum Out-Of-Square	.064" (1.62 mm)

CAMSHAFT SPECIFICATIONS**CAMSHAFT**

Application	In. (mm)
End Play	
Standard	.0028-.0074 (.07-.19)
Maximum	.008 (.20)

1996 Mazda MX-5 Miata

1995-96 ENGINES 1.8L 4-Cylinder

Journal Diameter	1.0213-1.0222 (25.940-25.965)
Maximum Journal Out-Of-Round	.0012 (.03)
Maximum Journal Runout	.0012 (.03)
Journal Oil Clearance	
Standard	.0014-.0031 (.035-.081)
Maximum	.006 (.15)
Lobe Height	
Standard	
Intake	1.7360 (44.094)
Exhaust	1.7559 (44.600)
Minimum	
Intake	1.7281 (43.894)
Exhaust	1.7480 (44.400)

VALVE LIFTERS SPECIFICATIONS**VALVE LIFTERS**

Application	In. (mm)
Bore Diameter	1.1811-1.1821 (30.000-30.025)
Lifter Diameter	1.1795-1.1802 (29.959-29.975)
Oil Clearance	
Standard	.0010-.0026 (.025-.066)
Maximum	.0071 (.180)